

Algorithms of Chromatic Dispersion Equalization in Coherent Optical Communication Systems

João Luís Filipe Santos, Instituto Superior Técnico

Abstract — In order to respond to the technologic society expectations and satisfying the nowadays search of services who required a high spectral efficiency, emerge an interest about coherent optical systems, that allows multi-level modulation formats and digital signal processing. So, the study of performance of equalization algorithms at digital domain is essential in order to get the best solutions.

The purpose of this paper is to describe the optical homodyne receiver, show the results about chromatic dispersion equalization and study the performance by signal-to-noise ratio estimation (SNR). Initially, the paper describes the homodyne detection and chromatic dispersion and then is presented SNR estimation techniques and equalization algorithms. At first the fixed chromatic dispersion equalization is approached by Overlap-Save algorithm and later the residual chromatic dispersion equalization (resulting from the variation of fiber dispersion parameter due to thermal variations) by LMS algorithm.

Keywords — Coherent optical system, DSP, SNR, Overlap-Save and LMS.

I. INTRODUCTION

The first optical transmission systems used to use binary amplitude modulation (OOK), where the information is recovered using a photodetector in a direct detection scheme [1]. Due to the high receiver sensitivity of the receivers, coherent optical transmission systems were investigated extensively in the eighties of last century. The invention, in 1990, and the rapid progress of erbium-doped fiber amplifiers (EDFAs) in the high-capacity wavelength-division multiplexed (WDM) systems employing direct modulation made this system very attractive. By this reasons and due is high complexity, the development of coherent technologies was delayed for nearly 20 years [1]. However, with the increase of demand for larger bit rates, WDM systems with amplification reached a saturation point and became essential to maximize the spectral efficiency [2]. In order to ensure this demand, rebirth in 2005, the interest in coherent optical systems that allows multi-level modulation formats and digital signal processing with the purpose of signal equalization [1].

II. COHERENT OPTICAL RECEIVER

The fundamental concept behind coherent detection is to take the product of electric fields of the modulated signal light and the continuous-wave (CW) local oscillator (LO). Figure 1 shows the configuration of the coherent optical receiver.

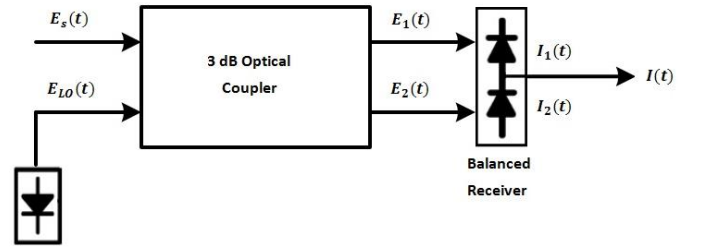

Fig.1: Configuration of the coherent optical receiver.

Let the optical signal incoming from the transmitter be [3]

$$E_s(t) = A_s(t) \exp(j\omega_s t) \cdot \hat{u}_s, \quad (1)$$

where $A_s(t)$ is the complex amplitude, ω_s the angular frequency and \hat{u}_s polarization vector. Similarly, the electric field of LO prepared at the receiver can be written as [3]

$$E_{LO}(t) = A_{LO} \exp(j\omega_{LO} t) \cdot \hat{u}_{LO}, \quad (2)$$

where A_{LO} is the constant complex amplitude and ω_{LO} the angular frequency of LO. The complex amplitudes $A_s(t)$ and A_{LO} are related to the signal power P_s and the LO power P_{LO} by $P_s(t) = |A_s(t)|^2/2$ and $P_{LO} = |A_{LO}|^2/2$, respectively.

Balanced detection is usually introduced into the coherent receiver as a means to suppress the dc component and maximize the signal photocurrent. Considering that signal and LO are co-polarized, the balanced detector output can be written as [3]

$$I(t) = 2R\sqrt{P_s(t)P_{LO}} \cdot \cos\{\omega_{IF}t + \theta(t) + \varphi_n(t)\}, \quad (3)$$

where ω_{IF} is the intermediate frequency given by $\omega_{IF} = |\omega_s - \omega_{LO}|$, R is the responsivity of the photodiode, $\theta(t)$ is phase modulation and $\varphi_n(t)$ is the total phase noise is given by [3]

$$\varphi_n(t) = \varphi_{ns}(t) - \varphi_{nLO}(t), \quad (4)$$

where $\varphi_{ns}(t)$ is laser phase noise and φ_{nLO} is the local oscillator phase noise.

In terms of configuration, there are two types of coherent optical receivers: homodyne and heterodyne. In homodyne receivers, local oscillator and laser have the same frequency and so ω_{IF} is zero and the photocurrent is a baseband signal. In heterodyne receivers, the frequencies are different and the photocurrent has an intermediate frequency [3]. In this paper, only the homodyne receiver is presented.

A. Homodyne Receiver

In homodyne receiver, the output photocurrent is given by

$$I(t) = 2R\sqrt{P_s(t)P_{LO}} \cdot \cos\{\theta(t) + \varphi_n(t)\}, \quad (5)$$

However, this equation only gives the in-phase component of modulated signal and the quadrature component cannot be detected. Therefore, this type of homodyne receivers is not able to extract the full information on the signal complex amplitude.

The solution for this problem is the implementation of phase diversity in homodyne receiver, where the 3-dB optical coupler is replaced by a 90° optical hybrid. Configuration of the phase diversity homodyne receiver is shown in figure 2 [3].

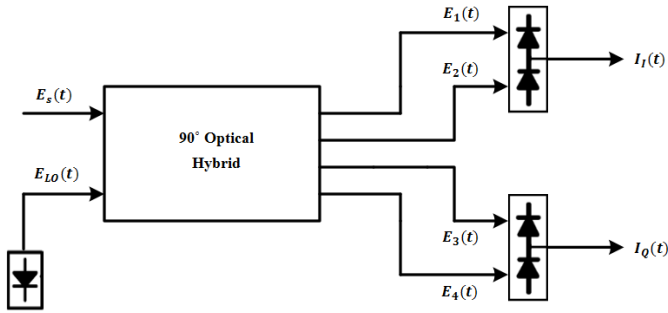

Fig. 2: Configuration of the phase-diversity homodyne.

Output photocurrents from balanced photodetectors are then given as

$$I_I(t) = R\sqrt{P_s(t)P_{LO}} \cdot \cos[\theta(t) + \varphi_n(t)], \quad (6)$$

$$I_Q(t) = R\sqrt{P_s(t)P_{LO}} \cdot \sin[\theta(t) + \varphi_n(t)]. \quad (7)$$

III. CHROMATIC DISPERSION

The chromatic dispersion manifested by a temporal extension of the pulses along the propagation in the optical fiber [4] and it becomes a serious impairment when bit rate is higher than 10 Gbit/s [5]. This phenomenon is caused by the inability to transmit purely monochromatic optical pulses and it is associated with the fact that the optical fiber is a

dispersive element. As the pulse group velocity is a function of wavelength, the spectral components of a data pulse have a delay each other after propagation along the fiber, causing an expansion in the time domain and causing inter-symbolic interference [4].

Ignoring the PMD and non-linear effects and considering only the fiber chromatic dispersion and attenuation, the electric field of the optical signal propagated in the direction z along the fiber can be described by

$$\frac{\partial E}{\partial z} + j\frac{\beta_2}{2}\frac{\partial^2 E}{\partial t^2} - \frac{\beta_3}{6}\frac{\partial^3 E}{\partial t^3} + \frac{\alpha}{2}E = 0, \quad (8)$$

where α is the attenuation coefficient and β_2 and β_3 are related to chromatic dispersion and they can be obtained from the propagation constant $\beta(\omega)$. The β_2 parameter is called group velocity dispersion (GVD) and is given by [6]

$$\beta_2 = \left. \frac{\partial^2 \beta(\omega)}{\partial \omega^2} \right|_{\omega=\omega_0} = -\frac{\lambda_0^2 D_{\lambda_0}}{2\pi c}, \quad (9)$$

where ω_0 is the reference angular frequency where GVD is evaluated, λ_0 is the Wavelength and D_{λ_0} is his dispersion parameter, expressed in ps/nm/km. The β_3 parameter is the second order GVD and it accounts for the change of GVD with angular frequency. It's given by [7]

$$\beta_3 = \left. \frac{\partial^3 \beta(\omega)}{\partial \omega^3} \right|_{\omega=\omega_0} = \left(\frac{\lambda_0^2}{2\pi c} \right)^2 S_{\lambda_0} + \frac{\lambda_0^3 D_{\lambda_0}}{2\pi^2 c^2}, \quad (10)$$

where S_{λ_0} is the slope of the dispersion parameter. Typically, to express the fiber chromatic dispersion parameter D is used instead of β_2 parameter [6]. For example, figure 3 shows the variation of the parameter D as a function of wavelength into a standard single mode-fiber (SSMF) [1].

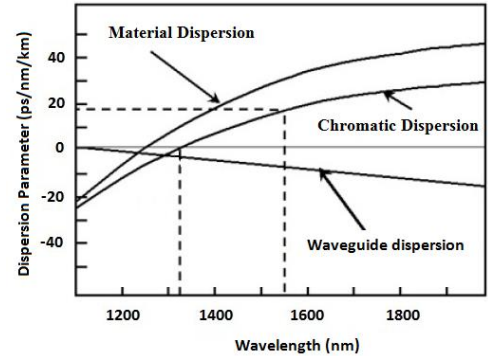

Fig. 3: Variation of D as a function of wavelength into a SSMF.

As can be seen in figure 3, the SSMF introduces D equal to 0 ps / nm / km at 1310 nm and D equal to 16 ps / nm / km at 1550 nm. Whereas the absence of attenuation so as to separately understand the effect of chromatic dispersion and knowing that β_3 parameter has little weight compared with β_2 parameter, it results in a linear Equation given by [6]

$$\frac{\partial E}{\partial z} + j \frac{\beta_2}{2} \frac{\partial^2 E}{\partial t^2} = 0. \quad (11)$$

The equation can be solved in the frequency domain by expression 12 followed by transformation in time domain by using inverse fast Fourier transform (IFFT) such is described by 13 [6].

$$\frac{E_{out}(f)}{E_{in}(f)} = \exp\left(-j \frac{D\lambda_0 \cdot \lambda_0^2 \cdot \pi \cdot (f - f_0)^2 \cdot L}{c}\right), \quad (12)$$

$$E_{out}(t) = IFFT\{E_{out}(f)\}. \quad (13)$$

IV. SNR ESTIMATION FOR THE AWGN CHANNEL

The Signal-to-Noise Ratio (SNR) is a performance metric that evaluates the quality of communication and as such a correct measure is essential [8]. Whereas only the received signal is corrupted by additive white gaussian noise (AWGN), SNR can be estimated from the gaussian distribution curves of the received points [9] or from the error vector magnitude (EVM) [10]. In this paper only last is presented.

EVM can be defined as the root-mean-squared (RMS) value of the difference between a collection of measured symbols and ideal symbols. The EVM can be represented as [10]

$$EVM_{RMS} = \sqrt{\frac{P_{err_average}}{P_{simbolo_average}}}, \quad (14)$$

where $P_{simbolo_average}$ is the average power of all modulation symbols, which is given by the average distance from the origin of all modulation symbols. $P_{err_average}$ is the average error power of all received symbols. The Symbol error power is given by the vector difference between the received symbol and the sent Symbol.

In data-aided receivers there is knowledge of the truly sent symbols and the relation between SNR and EVM is given by

$$EVM = \sqrt{\frac{1}{SNR}}. \quad (15)$$

In non-data-aided receivers the estimation of symbols sent is made taking into account the decision region received symbols and as such, previous expression can be applied only when the received symbols are equal to the symbols sent. Otherwise, the EVM is estimated smaller than the actual and estimated SNR is greater than the real.

V. EQUALIZATION ALGORITHMS

The performance of a high speed optical fiber transmission system is severely affected by phase noise, chromatic dispersion, polarization mode dispersion and the nonlinear effects [1]. Digital signal processing (DSP) allows the implementation of algorithms for the compensation of these impairments imposed by the optical system.

Considering that signal and LO are co-polarized and taking into account the chromatic dispersion, polarization mode dispersion and the lasers phase noise, the block diagram constituting the DSP circuit is typically composed of a sequence of operations shown in figure 4 [3].

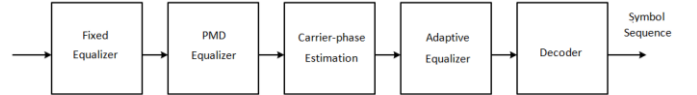

Fig. 4: DSP block diagram.

In this paper is presented the fixed equalizer by Overlap-Save algorithm and the adaptive equalizer by LMS algorithm. The first allows mitigate the fixed chromatic dispersion and the second allows mitigate the residual chromatic dispersion which resulting from the variation of the dispersion parameter with thermal variations.

A. Overlap-Save

The schematic of equalization in the frequency domain with the overlap-save method is illustrated in figure 5 [11].

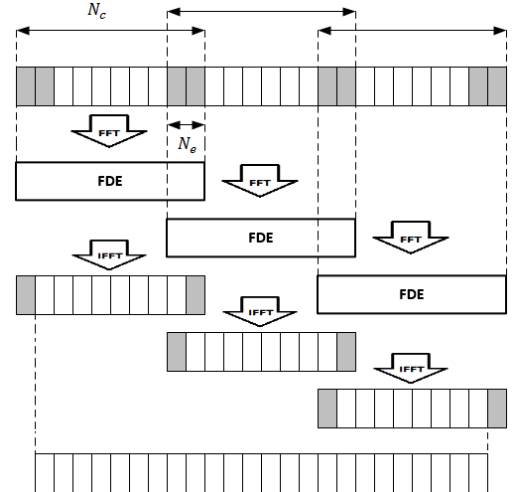

Fig. 5: Overlap-Save method.

The samples to equalize are divided into overlapping blocks of size N_c and designated with overlapping size N_e . Each block is applied to fast Fourier transform (FFT) and then

is performed the equalization in the frequency domain (FDE) using fixed coefficients calculated by [11]

$$G_c(z, f) = \exp\left(j \frac{D \lambda^2 \pi z f^2}{c}\right), \quad (16)$$

where D is the fiber parameter dispersion, λ is the central wavelength of the optical signal, z is the fiber length, c is the speed of light and f is the frequency electrical signal and must be limited according to the inequation [11]

$$-\frac{F_s}{2} \leq f \leq \frac{F_s}{2}, \quad (17)$$

where F_s is the sampling frequency of analog-to-digital converter. Subsequently, the data streams are transformed into time domain by IFFT, as shown in figure 5. Finally, bilateral N_e samples of each block are symmetrically disposed and the resulting blocks are combined [1]. The value of N_e is the fundamental parameter of this method and should obey the inequality 18 [11]:

$$N_e > \frac{c L D F_s f_{max}}{f_c^2}, \quad (18)$$

where f_{max} is the maximum frequency of the transmitted signal [11]. The minimum number of coefficients of a filter used to equalize the fixed chromatic dispersion is given by [12]

$$N_{c_min} = \left\lceil \frac{\tau_{CD}}{T_{samp}} \right\rceil, \quad (19)$$

where τ_{CD} is dispersive length size and is given by

$$\tau_{CD} = \frac{c}{f_c^2} \cdot |D| \cdot L \cdot B_{opt}, \quad (20)$$

where B_{opt} is the signal bandwidth.

B. LMS

The LMS adaptive filter is a filter that adapts automatically from the least squares algorithm [13] and his scheme is illustrated in figure 6.

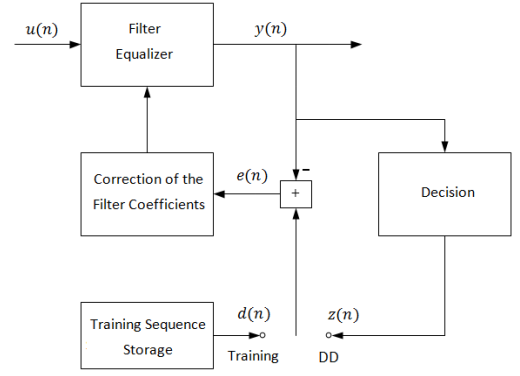

Fig. 6: LMS Block Diagram.

The principle of LMS filter is given by three equations. The first is the determination of the complex magnitude of the equalized symbol and is given by [1]

$$y(n) = \vec{\omega}^H(n) \cdot \vec{u}(n), \quad (21)$$

where $\vec{u}(n)$ is the vector with the complex magnitudes of received symbols, $\vec{\omega}(n)$ is the vector of the coefficients and $\vec{\omega}^H(n)$ is the Hermitian transform of $\vec{\omega}(n)$. The second equation is the calculation error between the equalized symbol and decided symbol and is given by [1]

$$e(n) = z(n) - y(n), \quad (22)$$

where $z(n)$ is the complex magnitude of the symbol decided according to the decision region which is the symbol equalized. The third equation is the calculation of new filter coefficients and is given by [1]

$$\vec{\omega}(n+1) = \vec{\omega}(n) + \mu \cdot \vec{u}(n) \cdot e^*(n), \quad (23)$$

where $e^*(n)$ is the conjugation of $e(n)$ and μ is a real coefficient called algorithm step size. In order to guarantee the convergence of tap weights vector $\vec{\omega}(n)$, the step size μ needs to satisfy the condition given by

$$0 < \mu < \frac{1}{\lambda_{max}}, \quad (24)$$

where λ_{max} is the largest eigenvalue of the correlation matrix given by

$$R = \vec{u}(n) \cdot \vec{u}^H(n). \quad (25)$$

One feature that hinders the application of this algorithm is the need for initialization of the coefficients. One way to make this boot is to apply a training sequence (symbols known sequence inserted into the sequence of digital information) to adapt the equalizer filter. It is defined that in this phase the algorithm is in training mode, where the equation that calculates the error is given by [14]

$$e(n) = d(n) - y(n), \quad (26)$$

where $d(n)$ is the complex magnitude of the sent symbol known training sequence. After being reached convergence, the algorithm moves to the designated dedicated mode decision (DD) that works without any training support. In this operation mode, the equation that calculates the error is given by expression 22 [14].

In this work, in order to explore the use of SNR estimators as convergence criterion, it was decided that the transition to the DD mode is carried out after a number of consecutive equalized symbols possess a particular required SNR. If the goal set is to get a null SER, the required SNR is related to the distance between two modulation adjacent symbols.

Considering the case of M-QAM modulation, this distance is equal to $2\sqrt{E_0}$. Thus, for a symbol is in the correct decision region, its error power should be less than E_0 . Whereas the average power of all symbols of the modulation is unitary, the required SNR is given, in dB, by

$$SNR_{req} = 10 \log_{10} \left(\frac{1}{E_0} \right). \quad (27)$$

Usually, the LMS algorithm uses only previous symbols corresponding to a symbol determined to equalize. However, this work has also been studied the algorithm performance using preceding and following symbols. In order to distinguish these two configurations, hereinafter, the algorithm that only considers previous symbols is designated by LMS_Pre and the algorithm that considers previous and subsequent symbols is designated by LMS_Dual.

LMS_Pre e LMS_Dual

Whereas it intends to make a sequence of symbols corrupted by residual chromatic dispersion, to equalize a particular symbol, the LMS algorithm uses a number of previous symbols equal to N_{eq_ant} and a number of subsequent symbols equal to N_{eq_post} , which is zero in the LMS_Pre Algorithm. Therefore, the LMS equalizer does not equalize the first N_{eq_ant} symbols and the last N_{eq_post} symbols. The number of equalizer filter coefficients is given by

$$L_{eq} = N_{eq_ant} + N_{eq_post} + 1. \quad (28)$$

Given the LMS_Pre algorithm and considering that are used 2 previous symbols, the figure 7 illustrates a sequence of 13 symbols corrupted by chromatic dispersion, the vector $u(n)$ constitution along the algorithm and the sequence of equalized symbols. The vector $u(1)$ consists of the first three symbols of the sequence containing chromatic dispersion, the vector $u(2)$ consists in the symbols s_2 until s_4 and so on for all values of n . Shaded symbols are those that will be performed at each time n .

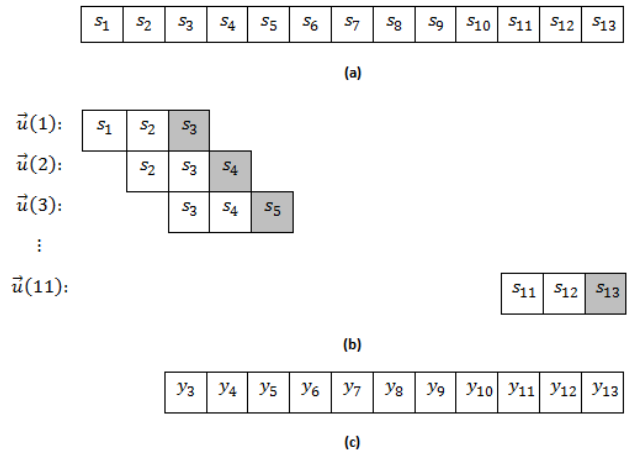

Fig. 7: (a) Sequence of 13 symbols corrupted by chromatic dispersion. (b) Variation vector u along Algorithm. (c) Sequence of equalized symbols.

Given the LMS_Dual algorithm and considering that are used 2 previous symbols and 1 subsequent symbol, the figure 8 illustrates a sequence of 13 symbols corrupted by chromatic dispersion, the vector $u(n)$ constitution along the algorithm and the sequence of equalized symbols. The vector $u(1)$ consists of the first four symbols of the sequence containing chromatic dispersion, the vector $u(2)$ consists in the symbols s_2 until s_5 and so on for all values of n . Shaded symbols are those that will be performed at each time n .

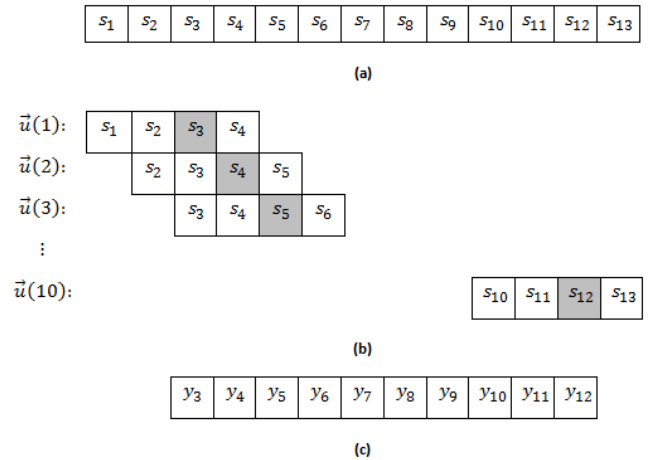

Fig. 8: (a) Sequence of 13 symbols corrupted by chromatic dispersion. (b) Variation vector u along algorithm. (c) Sequence of equalized symbols.

VI. RESULTS

This section presents the results corresponding to a communication affected by chromatic dispersion with variable dispersion parameter. The 4-QAM, 8-QAM, 16-QAM, 32-

QAM and 64-QAM were considered and it was defined that average power of all symbols of the modulation is unitary.

The section A shows the effects of chromatic dispersion in the constellation of received symbols. The section B shows the results of fixed chromatic dispersion equalization by Overlap-Save filter. Sections C and D show the results of residual chromatic dispersion equalization by LMS_Pre and LMS_Dual, respectively. In sections B, C and D is considered a fiber with 500 km.

A. Chromatic Dispersion Effects

The effects of chromatic dispersion increases with increasing fiber length and with increasing symbol rate.

Chromatic dispersion causes an unbalance of symbols around the ideal position and a rotation of the constellation as illustrated in figure 9, which illustrates the variation of a 16-QAM constellation with the variation of fiber length. It was considered a bit rate equal to 65 Gbit/s and a dispersion parameter equal to 16 ps/nm/km.

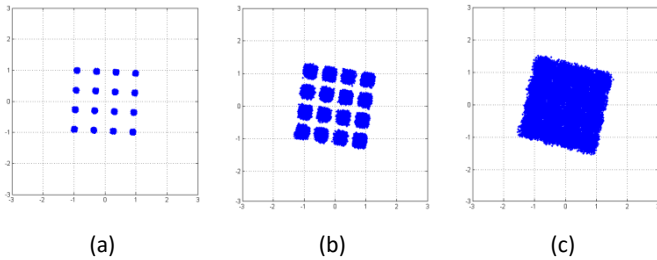

Fig. 9: Effects of chromatic dispersion for a length fiber equal to (a) 5 km, (b) 15 km e (c) 25 km.

B. Overlap-Save

The effects of residual chromatic dispersion are visible after equalization by Overlap-Save filter and are the result of their performance. The obtained results allow conclude that this performance decreases with increasing of D variation (ΔD) in relation to 16. For values of D with equal variations, his performance is similar and thus the performance achieved over the remaining equalization process is also similar.

The estimation of the SNR from the EVM, through the expression 15, becomes valid from the Overlap-Save equalization, where phase and quadrature components have a gaussian distribution, as is shown in figure 10, where it was considered a symbol rate equal to 20 GHz and a 16-QAM modulation.

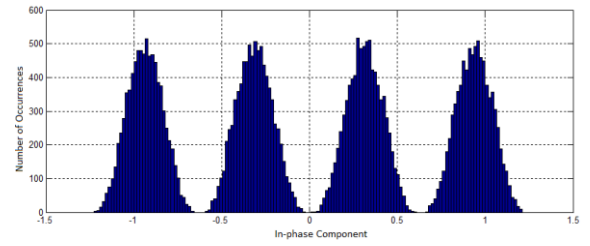

Fig. 10: Gaussian distribution of in-phase component.

When ΔD is zero, the Overlap-Save filter allows a perfect equalization of chromatic dispersion. However, when ΔD isn't zero, it results a residual chromatic dispersion after the Overlap-Save filter, as is shown in figure 11, where is shown the resulting constellations previous and after equalization when ΔD is equal to 0.25 ps/nm/km.

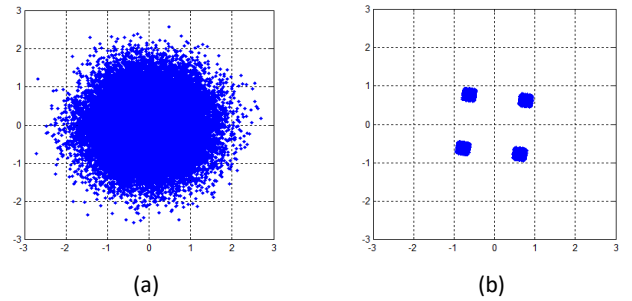

Fig. 11: (a) Pre-Equalization and (b) Pos-Equalization.

C. LMS_Pre

In this section is shown the LMS_Pre filter performance with the increase of the effects of chromatic dispersion by increasing the symbol frequency. It was considered a variation ΔD equal to 0.25 ps/nm/km, a step size μ equal to $1/15\lambda_{\max}$ and values of symbol rate equals to 20 GHz and 40 GHz.

The minimum number of coefficients of a filter used to equalize the fixed chromatic dispersion is given by expression 19. In order to calculate the minimum number of coefficients necessary to equalize the residual chromatic dispersion, has been found to fixed chromatic dispersion equivalent to the residual chromatic dispersion. As such, it obtained the symbol frequency for which the fixing has a chromatic dispersion equal to the EVM of the residual chromatic dispersion in the original case.

By simulation, it was found that the minimum number of coefficients is equal to 13 and 52 for values of symbol rate equals to 20 GHz and 40 GHz, respectively.

Whereas the minimum number of coefficients, figure 12 shows the evolution of the SNR obtained through the

algorithm and values required SNR in order to obtain a null SER.

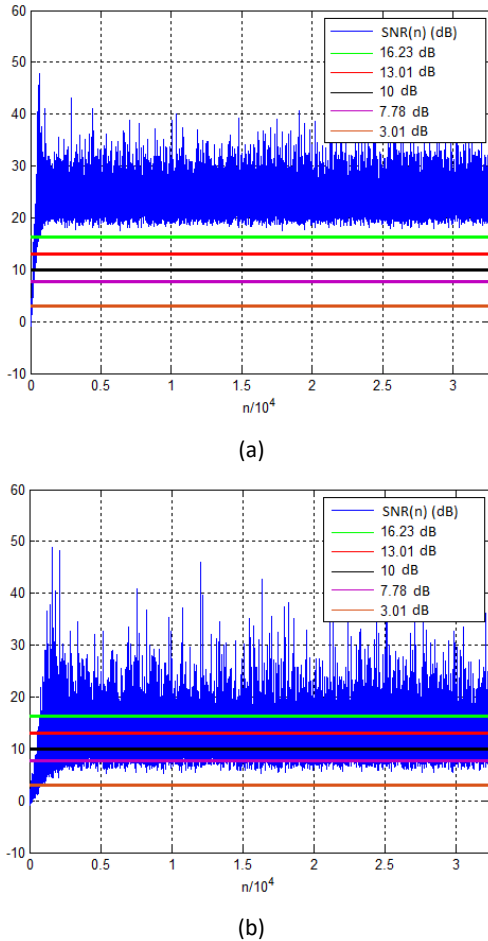

Fig. 12: Evolution of the SNR obtained for symbol rate equal to (a) 20 GHz and (b) 40 GHz.

Here, it is assumed that equalization is effective if the SNR obtained, after convergence, doesn't have values below SNR required in order to obtain a null SER.

Looking at figure 12, you can see that in the 20 GHz all modulations are feasible. However, in the case of 40 GHz, equalization is only effective in QAM-4 modulation.

Whereas modulation 4-QAM, figures 13 and 14 show the symbols constellation before and after LMS_Pre filter Symbol rates equals to 20 GHz and 40 GHz, respectively. After analysis of figure 12, it was defined that the transition to the DD mode is carried out after 200 consecutive symbols present a required SNR equal to 17 dB and 5 dB for 20 GHz and 40 GHz, respectively.

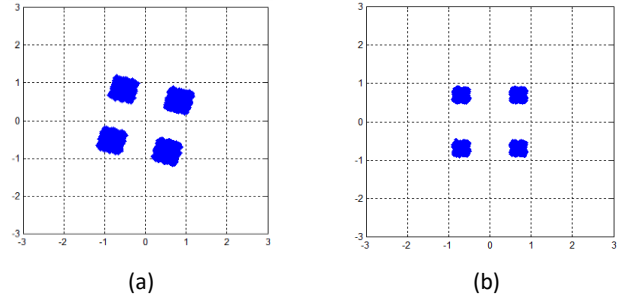

Fig. 13: Constellation in (a) Pre-Equalization and (b) Post-Equalization for 20 GHz.

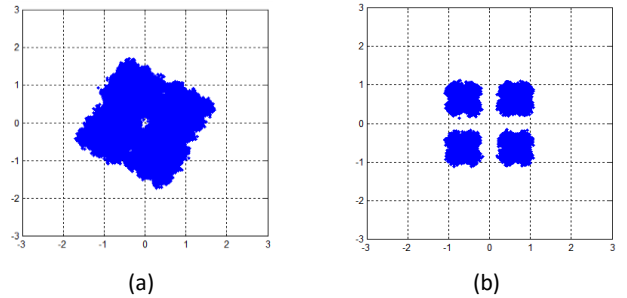

Fig. 14: Constellation in (a) Pre-Equalization and (b) Post-Equalization for 40 GHz.

D. LMS_Dual

The use of subsequent symbols in the LMS filter allows increasing the SNR obtained through the algorithm. In this section the performance of LMS_Dual algorithm is presented. It was considered a step size μ equal to $1/15\lambda_{\max}$, a symbol rate equal to 40 GHz and a variation D equal to 0.25 ps/nm/km.

After simulation, was found an increase in SNR value at the same time that the N_{eq_post} value increases and that this improvement stabilize since N_{eq_post} value is equal to 13.

The figure 15 shows the SNR obtained over the LMS_Pre and LMS_Dual algorithms considering N_{eq_ant} equal to 51 and N_{eq_post} equal to 13.

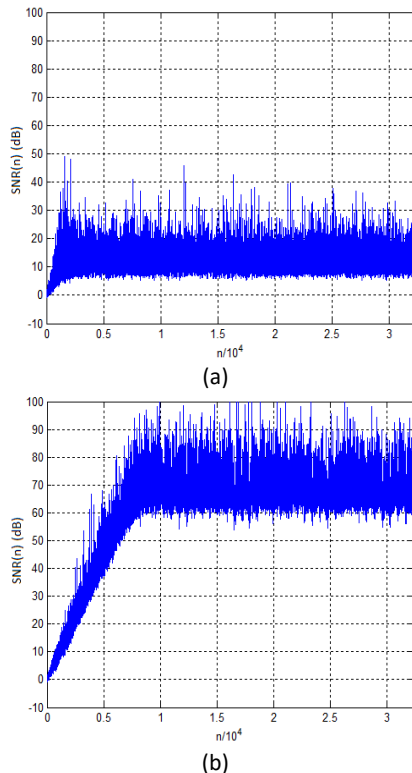
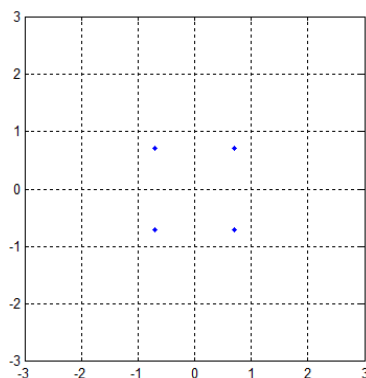

Fig. 15: Evolution of the SNR obtained in (a) LMS_Pre and (b) LMS_Dual.

After analysis of figure 15 (b), it was defined that the transition to the DD mode is carried out after 200 consecutive symbols present a required SNR equal to 50 dB. The constellation of equalized symbols in 4-QAM modulation is presented in figure 16.



VII. CONCLUSIONS

About Overlap-Save was possible to conclude that the equalization is extremely effective in fixed chromatic dispersion equalization, whereby its application would be enough if fiber dispersion parameter doesn't change.

With regard to the LMS algorithm, two distinct configurations were implemented. The first, only uses previous symbols to the symbol being equalized and the second uses, additionally, subsequent symbols. Comparing this two cases, was possible concluded that the use of subsequent symbols allows an increase of SNR obtained through the algorithm, making possible a less vulnerability to modulations with high spectral efficiency, bigger fiber length and bigger variations of dispersion parameter.

SNR estimation during the equalization process was revealed very interesting on LMS filter implementation, because it allows that useful information transmission just begins when a certain desired SNR is reached.

References

- [1] XU, Tianhua – *Digital Dispersion Equalization and Carrier Phase Estimation in 112-Gbit/s Coherent Optical Fiber Transmission System*. Estocolmo: 2011.
- [2] WINZER, Peter J. – Modulation and Multiplexing in optical communication systems. *IEEE LEOS NEWSLETTER*. Fevereiro, 2009.
- [3] KIKUCHI, Kazuro – *Coherent Optical Communications: Historical Perspectives and Future Directions*. In NAKAZAWA, Masataka [et al.] – *High Spectral Density Optical Communication Technologies*. Springer, 2010. p. 11-49.
- [4] ANDRÉ, Paulo [et al.] – Compensadores Adaptativos de Dispersão Cromática para Sistemas de Comunicação por Fibra Óptica. *IEEE Latin America Transactions*. Vol. 4, nº 5 (2006), p. 309 – 314.
- [5] SINGER, Andrew C. [et al.] – Electronic Equalization of Fiber Optic Links. *IEEE International Seminar on Communications*. Zurich: 2008.
- [6] ESSIAMBRE, René-Jean; WINZER, Peter J. – Advanced Modulation Formats. *Proceedings of the IEEE*. Vol. 94, nº 5 (2006).
- [7] CARTAXO, Adolfo – *Transmissão por Fibra Óptica*. IST, 2005.
- [8] ISLAM, Razibul; RAHMAN, Shahriar; SHAFIK, Rishad Ahmed – On the Extended Relationships Among EVM, BER and SNR as Performance Metrics. *International Conference on Electrical and Computer Engineering*. Daca: 2006.
- [9] KIM, In-Kyung; SHIN, Dong-Joon; SUNG Wonjin – Simple SNR Estimation Methods for QPSK Modulated Short Bursts. Global Telecommunications Conference. San Antonio, Texas: 2001.
- [10] ARSLAN, Hüseyin; MAHMOUD Hisham A. - Error Vector Magnitude to SNR Conversion for Nondata-Aided Receivers. *IEEE Transactions on Wireless Communications*. Vol. 8, nº 5 (2009).

- [11] RIBEIRO, Vitor Bedotto [et al.] – *Processamento de sinais para redes ópticas coerentes digitais de alta velocidade*. Campinas: 2011.
- [12] PEREIRA, Bruno [et al.] – Simulador de Sistemas de Comunicações Ópticas: OSIP 2012. *Electrónica e Telecomunicações*. Vol. 5, nº 5 (Dezembro de 2012).
- [13] ABRANTES, Sílvio A. – *Processamento Adaptativo de Sinais*. Lisboa: Fundação Calouste Gulbenkian, 2000.
- [14] PINTO, Nuno M. [et al.] – *Implementação de Algoritmos em FPGA para Estimação de Sinal em Sistemas Ópticos Coerentes*.